



Part No: CEP-1173

Description: piezo audio transducer

Date: 6/25/2007

Unit: mm

Page No: 1 of 4



Specifications

| | | |
|-----------------------|----------------------------|--------------------|
| Resonant frequency | 3.3 KHz \pm 0.5 | |
| Operating voltage | 3 ~ 28 V dc | |
| Current consumption | 7 mA max. | at 12 V dc |
| Sound pressure level | 82 db min. | at 30 cm / 12 V dc |
| Rated voltage | 12 V dc | |
| Tone | Continuous | |
| Operating temperature | -30 ~ +80° C | |
| Storage temperature | -40 ~ +95° C | |
| Dimensions | ϕ 32.0 x H13.5 mm | |
| Weight | 7.4 g max. | |
| Material | ABS UL-94 1/16" HB (Black) | |
| Terminal | Wire type | |
| RoHS | yes | |

Appearance Drawing

Tolerance: \pm 0.5

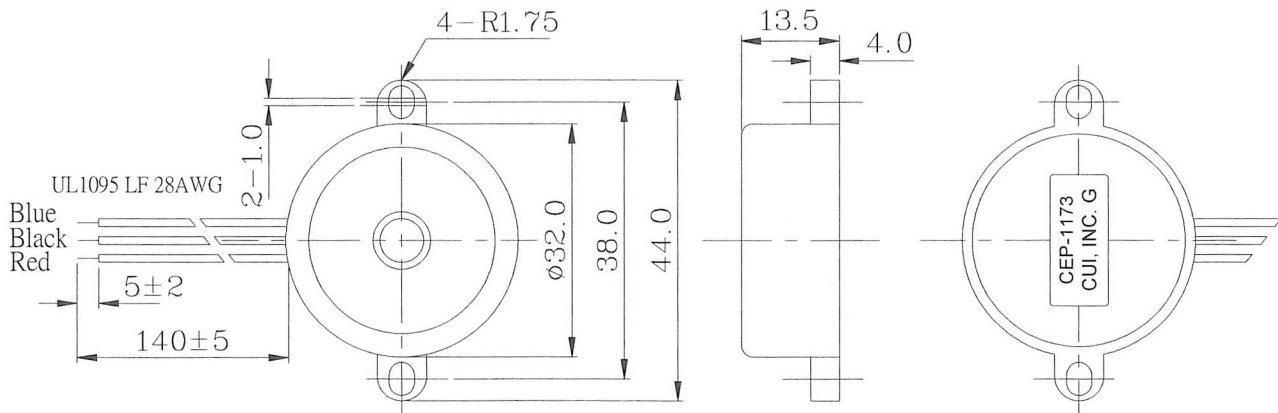

red wire ---M
 blue wire ---F
 black wire ---G

Measurement Method

1. S.P.L. Measuring Circuit

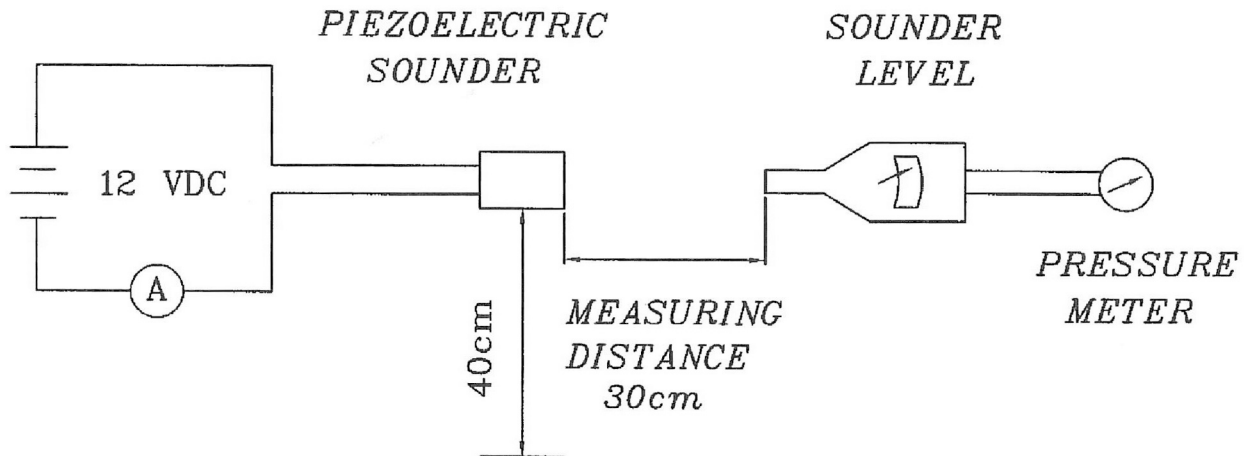

Mic : RION S.P.L meter UC30 or equivalent

2. The current consumption and the sound pressure level are measured by using the recommend driving circuit shown as below

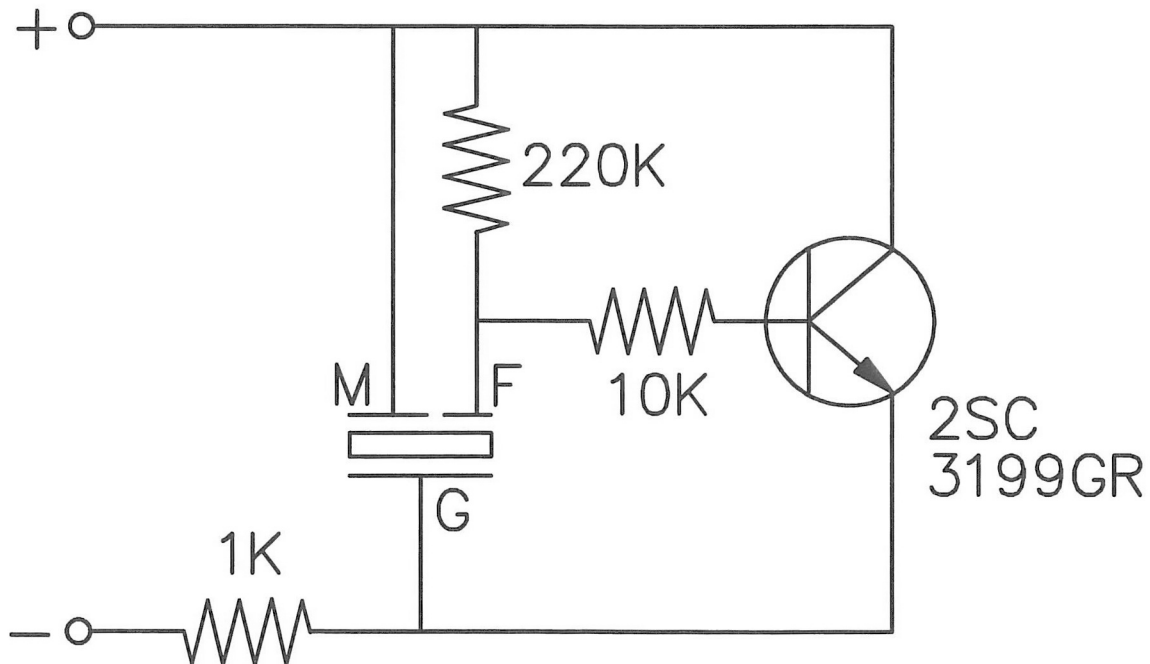



Part No: CEP-1173

Description: piezo audio transducer

Date: 6/25/2007

Unit: mm

Page No: 3 of 4

Mechanical Characteristics

| Item | Test Condition | Evaluation Standard |
|---------------------------------------|---|--|
| Solderability (Connector excepted) | Stripped wires of lead wires are immersed in rosin for 5 seconds and then immersed in a solder bath of $+270 \pm 5^{\circ}\text{C}$ for 3 ± 0.5 seconds. | 90% min. of the stripped wires will be wet with solder. (Except the edge of the terminal) |
| Terminal Mechanical Strength | The pull force should be applied to the double lead wire: Horizontal 3.0N (0.306kg) for 30 seconds Vertical 2.0N (0.204kg) for 30 seconds | No damage or cutting off. |
| Vibration | The buzzer shall be measured after applying a vibration amplitude of 1.5 mm with 10 to 55 Hz band of vibration frequency to each of the 3 perpendicular directions for 2 hours. | The value of oscillation frequency/current consumption should be $\pm 10\%$ of the initial measurements. The SPL should be within $\pm 10\text{dB}$ compared with the initial measurement. |
| Drop Test | The part will be dropped from a height of 75 cm onto a 40 mm thick wooden board 3 times in 3 axes (X, Y, Z) for a total of 9 drops. | |

Environment Test

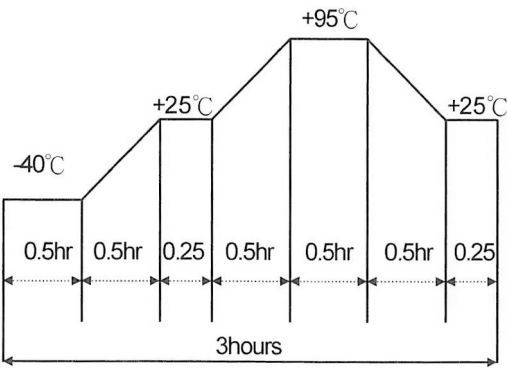
| Item | Test Condition | Evaluation Standard |
|------------------|---|---|
| High temp. test | After being placed in a chamber at $+95^{\circ}\text{C}$ for 240 hours. | The buzzer will be measured after being placed at $+25^{\circ}\text{C}$ for 4 hours. The value of the oscillation frequency/current consumption should be $\pm 10\%$ compared to the initial measurements. The SPL should be within $\pm 10\text{dB}$ compared to the initial measurements. |
| Low temp. test | After being placed in a chamber at -40°C for 240 hours. | |
| Humidity test | After being placed in a chamber at $+40^{\circ}\text{C}$ and $90 \pm 5\%$ relative humidity for 240 hours. | |
| Temp. cycle test | The part shall be subjected to 5 cycles. One cycle will consist of:  | |



Part No: CEP-1173

Description: piezo audio transducer

Date: 6/25/2007

Unit: mm

Page No: 4 of 4

Reliability Test

| Item | Test Condition | Evaluation Standard |
|-----------------------|---|--|
| Operating (Life Test) | <p>1. Continuous life test: The part will be subjected to 48 hours of continuous operation at +65°C with rated voltage applied.</p> <p>2. Intermittent life test: A duty cycle of 1 minute on, 1 minute off, a minimum of 5,000 times at room temp (+25 ±2°C) with rated voltage applied.</p> | <p>The buzzer will be measured after being placed at +25°C for 4 hours. The value of the oscillation frequency/current consumption should be ±10% compared to the initial measurements. The SPL should be within ±10dB compared to the initial measurements.</p> |

Test Conditions

| | | | |
|--------------------------|----------------------------|-----------------------|----------------------------|
| Standard Test Condition | a) Temperature: +5 ~ +35°C | b) Humidity: 45 - 85% | c) Pressure: 860-1060 mbar |
| Judgement Test Condition | a) Temperature: +25 ±2°C | b) Humidity: 60 - 70% | c) Pressure: 860-1060 mbar |

Packaging

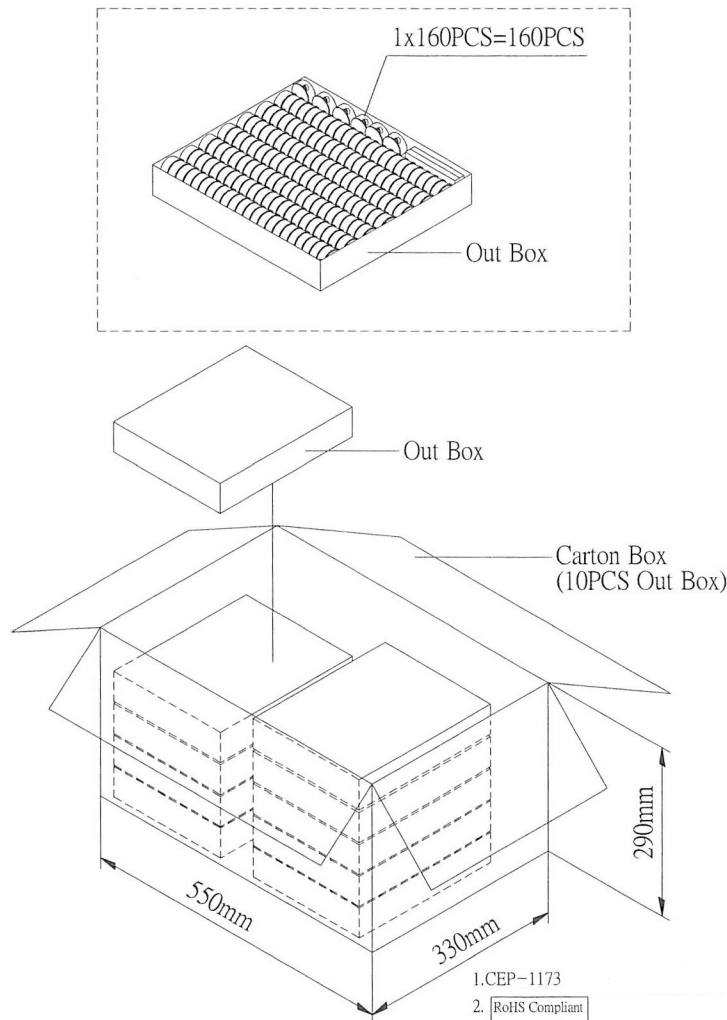

| | | |
|------------|-------------------|--------------------|
| Out Box | 310mmx248mmx49mm | 1x160PCS=160PCS |
| Carton Box | 550mmx330mmx290mm | 160PCSx10=1,600PCS |