

# Signal conditioner - MINI MCR-SL-I-U-0 - 2813541

Please be informed that the data shown in this PDF Document is generated from our Online Catalog. Please find the complete data in the user's documentation. Our General Terms of Use for Downloads are valid (<http://phoenixcontact.com/download>)



MCR 3-way isolating amplifier, for electrical isolation of analog signals, with screw connection, input signal: 0 mA ... 20 mA, output signal: 0 V ... 10 V

## Product Description

The 6.2 mm wide standard signal 3-way isolating amplifier MINI MCR-SL-I-U-... is used for electrical isolation, conversion, amplification and filtering of standard signals.

On the input side, 0...20 V mA or 4...20 mA are measured and made available at the module output as a galvanically isolated 0...10 V signal. Power (19.2 V DC to 30 V DC) can be supplied through connection terminal blocks on the modules or in conjunction with the DIN rail connector.

## Why buy this product

- Power supply possible via the foot element (TBUS)
- Low power consumption
- Entry-level alternative to configurable signal conditioners
- Highly-compact isolating amplifier for electrical isolation, conversion, amplification, and filtering of standard analog signals
- 3-way isolation
- Fixed signal combinations



## Key Commercial Data

Packing unit	1 STK
GTIN	
GTIN	4046356100601

## Technical data

### Note

Utilization restriction	EMC: class A product, see manufacturer's declaration in the download area
-------------------------	---

### Dimensions

Width	6.2 mm
Height	93.1 mm

# Signal conditioner - MINI MCR-SL-I-U-0 - 2813541

## Technical data

### Dimensions

Depth	102.5 mm
-------	----------

### Ambient conditions

Ambient temperature (operation)	-20 °C ... 65 °C
Ambient temperature (storage/transport)	-40 °C ... 85 °C
Maximum altitude	≤ 2000 m

### Input data

Number of inputs	1
Configurable/programmable	no
Current input signal	0 mA ... 20 mA
Max. input current	50 mA
Input resistance current input	approx. 50 Ω

### Output data

Number of outputs	1
Configurable/programmable	no
Voltage output signal	0 V ... 10 V
Max. output voltage	12.5 V
Short-circuit current	approx. 2 mA
Load/output load voltage output	≥ 10 kΩ
Ripple	< 20 mV <sub>PP</sub> (at 10 kΩ)

### Power supply

Nominal supply voltage	24 V DC
Supply voltage range	19.2 V DC ... 30 V DC (The DIN rail bus connector (ME 6,2 TBUS-2 1,5/5-ST-3,81 GN, Order No. 2869728) can be used to bridge the supply voltage. It can be snapped onto a 35 mm DIN rail according to EN 60715))
Max. current consumption	< 9 mA
Power consumption	< 200 mW

### Connection data

Connection method	Screw connection
Conductor cross section solid min.	0.2 mm <sup>2</sup>
Conductor cross section solid max.	2.5 mm <sup>2</sup>
Conductor cross section AWG min.	26
Conductor cross section AWG max.	12
Conductor cross section flexible min.	0.2 mm <sup>2</sup>
Conductor cross section flexible max.	2.5 mm <sup>2</sup>
Stripping length	12 mm
Screw thread	M3

### General

No. of channels	1
-----------------	---

# Signal conditioner - MINI MCR-SL-I-U-0 - 2813541

## Technical data

### General

Maximum transmission error	≤ 0.1 % (of final value)
Maximum temperature coefficient	< 0.01 %/K
Temperature coefficient, typical	< 0.002 %/K
Limit frequency (3 dB)	approx. 100 Hz
Step response (10-90%)	approx. 3.5 ms
Electrical isolation	Basic insulation according to EN 61010
Overvoltage category	II
Degree of pollution	2
Rated insulation voltage	30 V AC
Test voltage, input/output/supply	1.5 kV (50 Hz, 1 min.)
Electromagnetic compatibility	Conformance with EMC directive
Noise emission	EN 61000-6-4
Noise immunity	EN 61000-6-2 When being exposed to interference, there may be minimal deviations.
Color	green
Housing material	PBT
Mounting position	any
Assembly instructions	The T connector can be used to bridge the supply voltage. It can be snapped onto a 35 mm DIN rail according to EN 60715.
Conformance	CE-compliant
ATEX	# II 3 G Ex nA IIC T4 Gc X
UL, USA/Canada	UL 508 Recognized
	Class I, Div. 2, Groups A, B, C, D T4
GL	GL EMC 2 D
Fire protection for rail vehicles (DIN EN 45545-2) R22	HL 1 - HL 2
Fire protection for rail vehicles (DIN EN 45545-2) R23	HL 1 - HL 2
Fire protection for rail vehicles (DIN EN 45545-2) R24	HL 1 - HL 2

### EMC data

Designation	Electromagnetic RF field
Standards/regulations	EN 61000-4-3
Typical deviation from the measuring range final value	5 %
Designation	Fast transients (burst)
Standards/regulations	EN 61000-4-4
Typical deviation from the measuring range final value	5 %
Designation	Conducted interferences
Standards/regulations	EN 61000-4-6
Typical deviation from the measuring range final value	5 %

### Standards and Regulations

Electromagnetic compatibility	Conformance with EMC directive
Noise emission	EN 61000-6-4

# Signal conditioner - MINI MCR-SL-I-U-0 - 2813541

## Technical data

### Standards and Regulations

Connection in acc. with standard	CUL
Standards/regulations	EN 61000-4-2
Designation	Electromagnetic RF field
Standards/regulations	EN 61000-4-3
	EN 61000-4-4
	EN 61000-4-5
Designation	Conducted interferences
Standards/regulations	EN 61000-4-6
Electrical isolation	Basic insulation according to EN 61010
Conformance	CE-compliant
ATEX	# II 3 G Ex nA IIC T4 Gc X
UL, USA/Canada	UL 508 Recognized
	Class I, Div. 2, Groups A, B, C, D T4
GL	GL EMC 2 D
Fire protection for rail vehicles (DIN EN 45545-2) R22	HL 1 - HL 2 HL 1 - HL 2 HL 1 - HL 2
Fire protection for rail vehicles (DIN EN 45545-2) R23	HL 1 - HL 2 HL 1 - HL 2 HL 1 - HL 2
Fire protection for rail vehicles (DIN EN 45545-2) R24	HL 1 - HL 2 HL 1 - HL 2 HL 1 - HL 2
Fire protection for rail vehicles (DIN EN 45545-2) R26	HL 1 - HL 2 HL 1 - HL 2 HL 1 - HL 2

### Environmental Product Compliance

REACH SVHC	Lead 7439-92-1
China RoHS	Environmentally Friendly Use Period = 50
	For details about hazardous substances go to tab "Downloads", Category "Manufacturer's declaration"

## Drawings

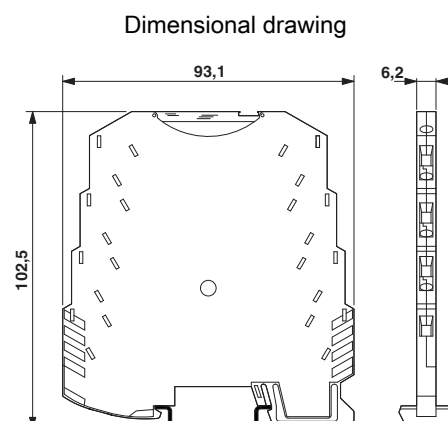
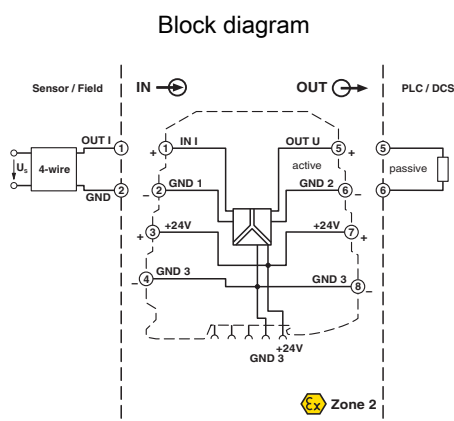

## Approvals

### Approvals

# Signal conditioner - MINI MCR-SL-I-U-0 - 2813541

## Approvals

### Approvals

UL Recognized / cUL Recognized / GL / EAC / cULus Recognized

---

### Ex Approvals

UL Listed / cUL Listed / ATEX / cULus Listed

---

### Approval details

UL Recognized		<a href="http://database.ul.com/cgi-bin/XYV/template/LISEXT/1FRAME/index.htm">http://database.ul.com/cgi-bin/XYV/template/LISEXT/1FRAME/index.htm</a>	FILE E 238705
cUL Recognized		<a href="http://database.ul.com/cgi-bin/XYV/template/LISEXT/1FRAME/index.htm">http://database.ul.com/cgi-bin/XYV/template/LISEXT/1FRAME/index.htm</a>	FILE E 238705
GL		<a href="http://exchange.dnv.com/tari/">http://exchange.dnv.com/tari/</a>	24916-05 HH
EAC			EAC-Zulassung
cULus Recognized		<a href="http://database.ul.com/cgi-bin/XYV/template/LISEXT/1FRAME/index.htm">http://database.ul.com/cgi-bin/XYV/template/LISEXT/1FRAME/index.htm</a>	

---

Phoenix Contact 2018 © - all rights reserved  
<http://www.phoenixcontact.com>

PHOENIX CONTACT GmbH & Co. KG  
Flachsmarktstr. 8  
32825 Blomberg  
Germany  
Tel. +49 5235 300  
Fax +49 5235 3 41200  
<http://www.phoenixcontact.com>