

Figure 1

## 1. INTRODUCTION

This instruction sheet covers the use and care of Terminating Modules 856196-[ ], used with Dual Modular Plug Terminator 1320840-[ ].

The terminating modules terminate the modular plug connectors listed in Figure 2, to create cable assemblies. During termination, terminators 1320840-1 and 1320840-2 will test the assembly for electrical circuit continuity. Terminator 1320840-3 will not test electrical circuit continuity.

For further information on Modular Interconnection System Products, refer to Catalog 82066.

Refer to Application Specifications 114-6016 (Modular Plug Connectors) and 114-6053 (High Performance Modular Plug Connectors) for contact inserter information, shielded cable stripping procedures, and cable stripping dimensions.

Read these instructions completely before using the tools.

When reading this document, pay particular attention to DANGER, CAUTION, and NOTE statements.



**DANGER** Denotes an imminent hazard which may result in moderate or severe injury.



**CAUTION** Denotes a condition which may result in product or equipment damage.

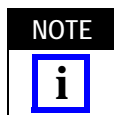

**NOTE** Highlights special or important information.

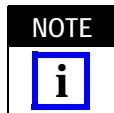

**NOTE** All dimensions on this sheet are in millimeters [followed by inches in brackets].

Reasons for reissue are in Section 9, REVISION SUMMARY.

## 2. DESCRIPTION

Terminating modules (Figure 1) fit interchangeably into the dual modular plug terminator. Each module features dual nesting areas for positioning the plugs; inserters for terminating modular plug contacts, and stuffers for terminating the primary and secondary strain relief. Since each feature is independently adjustable, crimp heights are easily adjusted to meet FCC specifications.

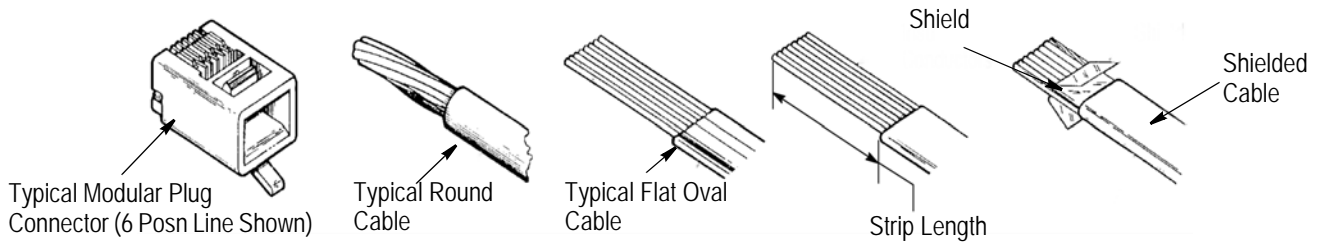

MODULAR PLUG		PART NUMBER	CABLE		TERMINATING MODULE NO. 856196-[ ]	STRIP LENGTH		
POSN	DESCRIPTION		TYPE	STYLE				
2	Line	641333	Stranded	Flat Oval	-1	A		
	Line	737743	Stranded	Flat Oval				
	Line	737746	Stranded	Flat Oval				
4	Handset	556200	Solid	Flat Oval	-3	A		
	Handset	641334	Stranded	Flat Oval				
	Handset	737628	Stranded	Flat Oval				
	Handset	737629	Stranded	Flat Oval				
	Handset	737344	Stranded	Flat Oval				
	Handset	737335	Stranded	Flat Oval				
	Line	556384	Solid	Flat Oval	-1			
	Line	641335	Stranded	Flat Oval				
	Line	737336	Stranded	Flat Oval				
	Line	737742	Stranded	Flat Oval				
	Line	737345	Stranded	Flat Oval				
	Line	737745	Stranded	Flat Oval				
	6	Blue - Small Conductor	557965	Solid	Flat Oval		-2	B
		Blue - Small Conductor	557967	Stranded	Flat Oval			
		8 X 4 Long	556586	Stranded	Flat Oval		-1	A
		Line	555042	Solid	Flat Oval			
Line		641337	Stranded	Flat Oval				
Line		554710	Stranded	Round				
Line		737747	Stranded	Flat Oval				
Line		737744	Stranded	Flat Oval				
Blue - Small Conductor		557970	Solid	Flat Oval				
Blue - Small Conductor		557971	Stranded	Flat Oval				
Offset		555238	Stranded	Round	-5	A		
Offset		555236	Solid	Flat Oval				
Offset		555237	Stranded	Flat Oval				
Long		555426	Solid	Flat Oval	-4	C		
Long		555176	Stranded	Flat Oval				
Long		555177	Stranded	Round				
Long - Shielded	555174	Stranded	Flat Oval					

**NOTE:** Small Conductor Products Are For .74-.86 [.029-.034] OD Conductors.  
 Regular Products Are For .89-.99 [.035-.039] OD Conductors.

**STRIP LENGTH:** A = 6.35 - 7.14 [.25 - .28] ;  
 B = 12.7-14.2 [.50-.56]; C = 14.2 [.56]

Figure 2 (Cont'd)

POSN	MODULAR PLUG		PART NUMBER	TYPE	STYLE	TERMINATING MODULE NO. 856196-[ ]	STRIP LENGTH
	DESCRIPTION						
8	Line		554720	Solid	Flat Oval	-2	B
	Line		554739	Stranded	Flat Oval		
	Line		557315	Solid	Round		
	Line		554169	Stranded	Round		
	Blue - Small Conductor		557972	Solid	Flat Oval		
	Blue - Small Conductor		557973	Stranded	Flat Oval		
	Keyed		555417	Solid	Flat Oval		
	Keyed		554743	Stranded	Flat Oval		
	Keyed		554170	Stranded	Round		
	Shielded	<i>556985 superseded by</i> →	569530	Solid	Round	1- -1	†
	Shielded	<i>555179 superseded by</i> →	569532	Stranded	Round		
	Shielded	<i>555178 superseded by</i> →	569542	Stranded	Flat Oval		
	Shielded-keyed	<i>557499 superseded by</i> →	569531	Solid	Round		
	Shielded-keyed	<i>556592 superseded by</i> →	569543	Stranded	Flat Oval		
	Line - High Performance		558530	Stranded	Round		
	Line - High Performance		569278	Solid	Round		
	Shielded - High Performance	<i>558593 superseded by</i> →	569552	Stranded	Round		
	Shielded - High Performance		569550	Solid	Round		
	‡‡	--	--	--	1- -2	‡‡	
10	Line		557963	Stranded	Round	-6	B

† See Application Specification 114-6053 for strip length information.

**STRIP LENGTH:**

<b>A</b>	<b>B</b>	<b>C</b>
6.35-7.14	12.7-14.2	14.2
[.25-.28]	[.50-.56]	[.56]

**NOTE:** Small Conductor Products are for .74-.86 [.029-.034] OD Conductors. Regular Products are for .89-.99 [.035-.039] OD Conductors.

‡‡ This Terminating Module is used to Terminate non-TE Connectors Without Secondary Strain Relief. Consult Product Engineering to Ensure Connector Capability.

Termination Module 856196-7 allows the operator to use two different module numbers at the same time. For example, Module No. 856196-7 allows the operator to simultaneously terminate product used with 856196-2 (on the left side) and product used with 856196-1 (on the right side).

TERMINATION MODULE NO.	PRODUCT	
856196-7	Product terminated by Module No. 856196-2	Product terminated by Module No. 856196-1

Figure 2 (End)

Dual Modular Plug Terminator 1320840-[ ] (see Customer Manual 409-10010) is a pneumatic power unit, terminators 1320840-1 and 1320840-2 have a circuit tester with cable hook-up and ground, and an AC/DC converter. Terminator 1320840-3 does not have a circuit tester.

The tester can be set to test specific plug sizes and contact arrangements. Test results are signaled by a beeper; specific information is displayed by means of a series of light-emitting diodes (LEDs) on the front panel of the tester.

Dual Modular Plug Terminator 1320840-1 is configured for use in 115 Vac systems. Dual Modular

Plug Terminator 1320840-2 is configured for use in 230 Vac systems. The noise levels produced by all machines vary between 82 dB and 87 dB at the operator position.

### 3. INSTALLING THE TERMINATOR

Refer to the appropriate Customer Manual 409-10010 for detailed installation instructions.

1. Connect terminator to regulated air supply of 551 kPa to 689 kPa [80 to 100 psi] at .47 liters/sec [1. scfm].

2. Connect free end of the green wire on the tester cable to a suitable ground (Terminators 1320840-1 and 1320840-2 only).

**4. INSTALLING THE MODULE** (Figure 3 and Figure 4)



*To avoid personal injury, DISCONNECT AIR SUPPLY before attempting to install, or remove, the module. A lockout valve has been provided in the air line.*

1. Connect cable from tester to the rear of module and tighten screws to secure cable connector. Check two single wire terminations on limit switch to the left of the tester cable (viewing from the rear of the module). Ensure that these wires are firmly connected to the limit switch at the topmost and bottommost terminals (normally-closed position). Verify the green wire on the tester cable is connected to the terminator and to a suitable ground on your AC outlet (Terminators 1320840-1 and 1320840-2 only).
2. Position the module so that the T-slot at the top will slide onto the arm; slide into place so that the module rests on the base plate. Tighten screws at the bottom front of the module, securing module to the base plate.
3. Reconnect the air supply to the terminator.
4. Run samples to inspect the crimp height and strain reliefs.

5. Adjust contact inserters (for proper crimp height measurement) and strain relief stuffers. Refer to Figure 3 and to the appropriate application specification.

- a. Lift the module ram mechanism off the module for ease in making adjustments.

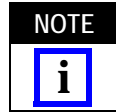

*If adjustments must be made after module installation, first remove the module, and then remove the ram. (See Figure 3.)*

- b. The inserters and stuffers are held to the ram by two 8-32 socket head cap screws at the front of the ram. Slightly loosen these screws so that the necessary adjustments can be made.
- c. Set the crimp height:
  - 1) Loosen locking setscrews at the rear of the ram head and loosen the back-up setscrews at least one full turn counterclockwise.
  - 2) Rotate the contact inserter adjustment screws clockwise to adjust the inserter downward until the inserters are at the correct height for the plugs. One full turn equals roughly 0.18 [.007]. Refer to the appropriate application specification for the correct height.
  - 3) Tighten the locking and back-up setscrews.

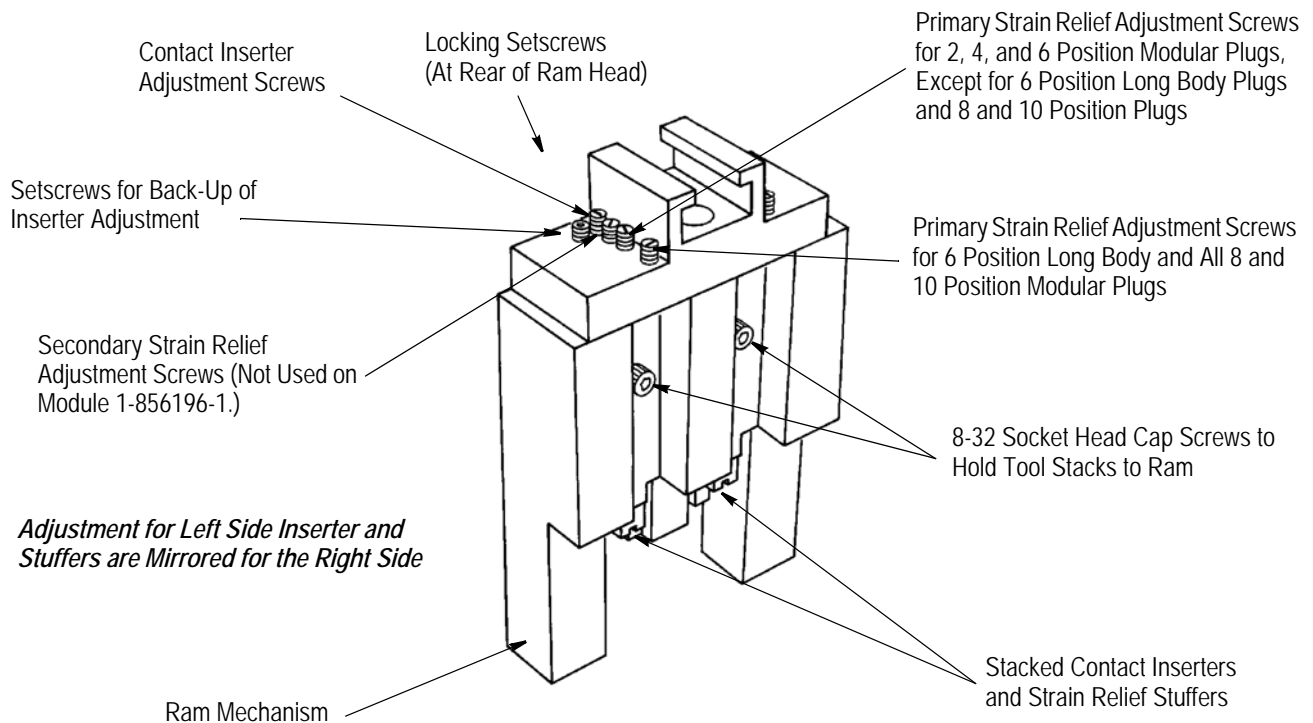

Figure 3

- d. Adjust the primary strain relief stuffers:
  - 1) Find the correct primary strain relief adjustment screws as shown in Figure 3, and ensure that the tool stack securing screws are loosened enough to make the required adjustments.
  - 2) Rotate the adjustment screws clockwise to adjust the primary strain relief stuffers downward. One rotation equals roughly 0.64 [.025].
- e. Adjust the secondary strain relief stuffers.
  - 1) Find the secondary strain relief adjustment screws as shown in Figure 3, and loosen them enough to make the required adjustments.
  - 2) Rotate screws clockwise to adjust the secondary strain relief stuffers downward. One rotation equals roughly 0.64 [.025].
- f. .Hold ALL strain relief stuffers in their up-most position, and tighten the 8-32 cap screws that hold the indenters and stuffers in place. Reposition ram on the module.

**5. TERMINATING AND TESTING PLUGS**  
(Terminators 1320840-1 and 1320840-2 Only)

**5.1. Tester Setup** (Figure 5)

- 1. Plug the miniature plug of the AC/DC converter into the tester power inlet (top hole on the left side)

and plug the base unit into the 120 Vac, 60 Hz receptacle (230 Vac, 50 Hz for Terminator 1320840-2). At power-up, the tester will respond with one long tone, followed by three short tones. The Wire Position LEDs will begin the "stand-by" LED pattern.

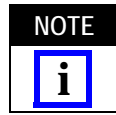

*Wire Position LEDs blink on and off in a fixed "back and forth" sequence.*

2. Determine the wiring-to-plug relationship of the cables you will be making: 1:1, 1:N, or crossed conductors.

3. Set the tester switches in the following manner (see Figure 5):

**1:1 or 1:N Orientation**

- a. Turn the Position Selector Switch to indicate the total number of contacts in the plug you are using.
- b. Place the 1:1/1:N Switch in the appropriate position.
- c. Set the Wire Position Switches for all the contacts that will have wires in them to the "I" position. Set switches for contacts that are unused, or open, in the "O" position.

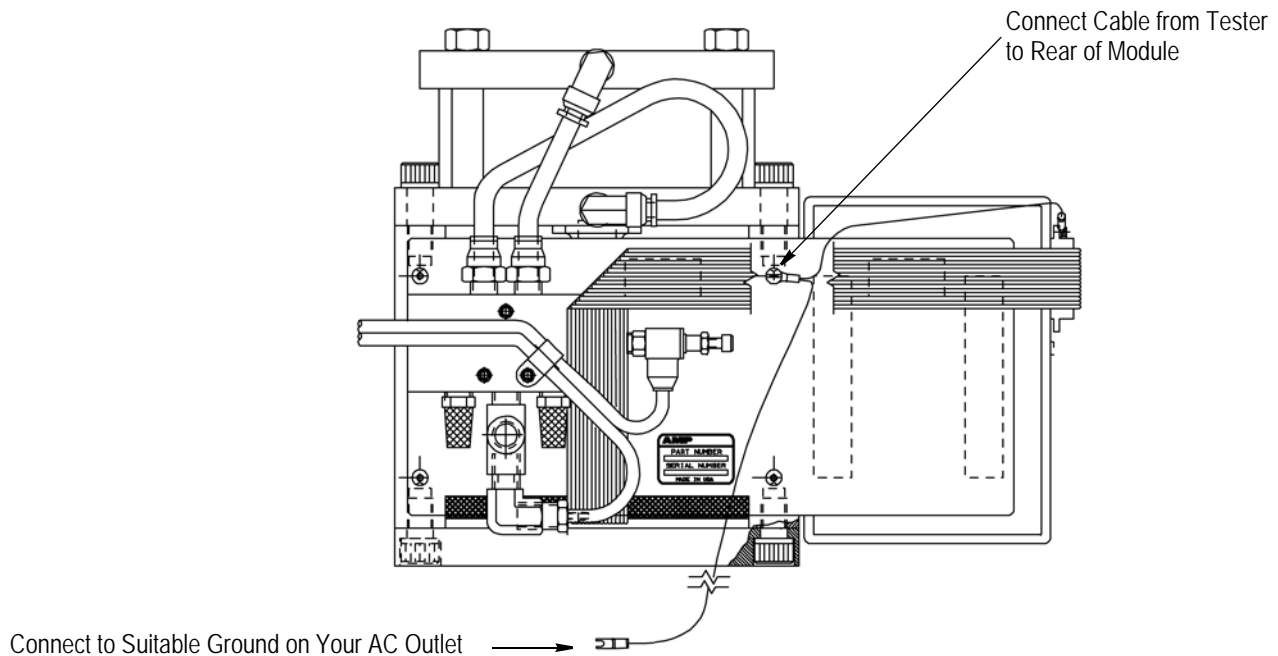

Figure 4

### Crossed Conductors

- a. Obtain a cable that fits the specifications you require (crossovers, open positions, etc.). Insert and fully latch both plugs in the terminator nest, with the plug release tab facing downward.

*Circuit Tester Switches and LEDs  
(For Terminators 1320840-1 and 1320840-2 Only)*

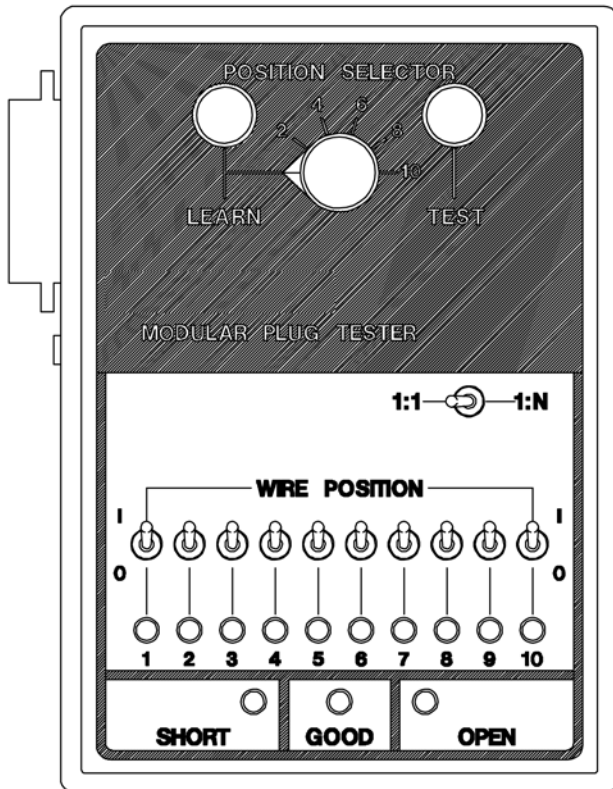

Figure 5

- b. Turn the Position Selector Switch to indicate the size plug you are using.

**NOTE** *The 1:1/1:N Switch and Wire Position Switches are disabled when using the LEARN mode, and can be left in any position.*

- c. Press and release the LEARN pushbutton. The wire Position LEDs will indicate a new pattern and a short tone will sound, indicating the tester has successfully examined and stored the cable's wiring pattern.
- d. Hold the cable assembly release down and remove the cable assembly from the nest. Turn the Position Selector Switch to the LEARN position.

### 5.2. Terminating Plugs

1. Strip the cable insulation outer jacket as shown in Figure 2. Do NOT strip the insulation from the

individual conductors. Refer to the appropriate application specification for proper shielded cable stripping procedures.

2. Insert stripped cables into the plugs, and insert the cables and plugs into the terminator nests.

- Be sure that cable conductors are oriented to the appropriate contact slots before inserting the conductors into the plugs.
- Be sure the cable conductors are bottomed in the contact slots of the plugs, and that they remain bottomed throughout the cycling of the terminator.
- Be sure that the plugs bottom in the terminator nest. The plug release tab MUST snap firmly into place.

3. Press the foot pedal to cycle the terminator. When termination is complete, the tester will automatically examine the cable assembly and respond with either a short tone or a long tone (see Figure 6). After the cable assembly is tested, hold the cable assembly release down and remove the cable assembly from the terminator.

**CAUTION** *Removing the cable assembly BEFORE a tone has sounded may cause good terminations to test as failures.*

**NOTE** *Any coupled cable assembly may be tested or re-tested inserting and latching the plugs into the terminator nest and pressing the TEST pushbutton.*

### 5.3. Inspecting Cable Assemblies

Inspect the crimps on the modular plugs using an indicator with a 0.25 [.010] diameter needle-point probe. See Application Specification 114-6016 for crimp height and other terminated plug criteria.

Problems associated with bad cable assemblies should be recorder to aid in troubleshooting. Check for the source of recurring problems in the following order:

1. Check the settings against your test cable.
2. Be sure you are terminating the correct combination of cable and plugs.
3. Check the crimp height and strain relief settings, and if necessary, make the corresponding adjustments on the module.
4. Inspect spring plungers to be sure they are all correctly resting on the contact probes.
5. Inspect and replace any defective mechanical tooling parts. Refer to Section 6, MAINTENANCE/INSPECTION of this instruction sheet. If the problem cannot be resolved, call the Tooling Assistance Center at 1-800-722-1111.

**TESTING SUMMARY**

1:1 / 1:N ORIENTATION		
TEST	CONDITION	TEST INDICATORS
The tester checks for open conductors.	One or more open conductors.	A long tone will sound and the OPEN LED will light. The Wire Position LEDs will also light, corresponding to the open conductors of the plug located in the right-hand nest. Note: If "opens" are found, the tester abandons further testing, therefore shorts that may have also been present will not be indicated.
If there are no open conductors, the tester checks for short circuits.	The cable assembly has two or more shorted conductors.	A long tone will sound and the SHORT LED will light. The Wire Position LEDs will also light, corresponding to the shorted conductors of the plug located in the right-hand nest.
No "opens" or "shorts" are found.	The cable assembly is considered good.	The tester will sound a short tone and the GOOD LED will light.
CROSSED CONDUCTORS		
TEST	CONDITION	TEST INDICATORS
With the Position Selector switch in the LEARN position, the tester compares the cable assembly against a "learned" cable pattern. When a cable assembly has a "learned" cable pattern, open conductors, as well as crossed conductors, are noted.	Contacts that were learned as "open" are found to have continuity to other conductors in the cable assembly.	The tester will sound a long tone, light both the OPEN and SHORT LEDs, and light the Wire Position LEDs corresponding to the connected conductors of the plug located in the right-hand side of the nest.
If there are no connections where there should be opens, the tester will conduct the "opens" test.	The cable assembly has one or more open conductors:	The tester will sound a long tone, the OPEN LED will light, and the Wire Position LEDs will light, corresponding to the open conductors of the plug located in the right-hand side of the nest.
If there are no opens present the tester performs the "shorts" test.	The cable assembly has two or more shorted conductors:	The tester will sound a long tone, the SHORT LED will light, and the Wire Position LEDs will light, corresponding to the open conductors of the plug located in the right-hand side of the nest.
The cable assembly passes all three tests.	The cable assembly is considered good.	The tester will sound a short tone and the GOOD LED will light.

Figure 6

**6. MAINTENANCE/INSPECTION**

These instructions have been established to ensure the continued quality and reliability of the tool.

It is recommended that each terminator be inspected immediately upon its arrival at your facility, to ensure that the tool has not been damaged during shipping and handling, and at its regularly scheduled intervals.

See Figure 7 for troubleshooting information.

1. At the end of each shift, clean the foreign particles from the tool using a soft, clean, lint-free cloth or brush. Make sure contact stuffers and strain relief stuffers are secured in place. Check the area under the baseplate for foreign matter and debris.

2. Inspect the terminator for secure engagement of the connectors and cable from the tester to the module, and the wires to the limit switch at the left rear of the module.

3. Lubricate the module ram, if necessary, with a THIN coat of high pressure grease. Do NOT lubricate excessively. Store in a clean, dry place.

**TROUBLESHOOTING**

PROBLEM	CAUSE	SOLUTION
<p>Tester's LEDs do not display the "standby" pattern, and the tester is unresponsive in general.</p>	<p>Power to the tester has been interrupted.</p>	<ol style="list-style-type: none"> <li>1. Be sure that the miniature plug of the AC/DC adaptor is fully inserted into the jack located through the top hole on the left-hand side of the tester.</li> <li>2. Remove the miniature plug from the tester. With the base unit still plugged into the power outlet, check the voltage output of the adaptor. A voltmeter should read between 9 and 11 volts DC-- outer ring of the plug positive, center hole negative. If the proper voltage is not present, check the wall outlet for proper AC line voltage. If the wall outlet voltage is adequate, replace the adaptor.</li> </ol>
<p>The tester falls dormant (no "standby" LED pattern) for approximately 1 to 2 seconds, then starts blinking all the LEDs and sounding a short tone, once every second.</p>	<ol style="list-style-type: none"> <li>1. The ribbon-cable from the tester to the module is loose or faulty.</li> <li>2. The two wires from the module printed circuit board to the limit switch are loose or connected incorrectly.</li> <li>3. The limit switch is faulty.</li> <li>4. The terminator ram has been "bottomed" for more than 2 seconds.</li> </ol>	<ol style="list-style-type: none"> <li>1. Check the ribbon-cable for tight connections, both at the tester and at the module printed circuit board. Tighten connections if necessary. Replace if necessary.</li> <li>2. Check the wire connections at the terminals of the limit switch for tightness, and for correct position: "COM" and "NC" terminals.</li> <li>3. Check the limit switch with a continuity meter between the COM and the NC terminals. These terminals should show continuity when the switch is not actuated, and open when the switch is actuated. Replace the switch if necessary.</li> <li>4. The operator's foot must be removed from the pedal after cycling the terminator, otherwise the ram will remain in the bottomed position.</li> </ol>
<p>While "learning" a cable pattern or testing a cable assembly against a "learned" cable pattern, the tester flashes all LEDs five times, and then resumes the "standby" LED pattern.</p>	<p>The memory component that stores the "learned" cable pattern is faulty.</p>	<p>Return the tester to TE for repair.</p>

For solutions to other problems, contact the Tooling Assistance Center at 1-800-722-1111.

Figure 7

**6.1. Daily Maintenance**

It is recommended that each operator of the terminator be aware of and responsible for the following steps of daily maintenance:



*Be sure to keep the terminator areas of the stuffers and nest areas especially clean. DO NOT oil or grease the termination areas of the stuffers or the contact slides.*

**6.2. Periodic Inspection**

Quality control personnel should perform regular inspections, record the results, and keep a record of inspections with the terminator, or supply the records to supervisory personnel responsible for the terminator.

It is recommended that inspection procedures be performed at least once a month. Your work environment, company standards, or amount of terminator use may dictate more frequent inspections.





*Failure to perform periodic inspection and cleaning can cause the module to make defective modular plug terminations leading to discontinuities on individual wire circuits.*

## 7. REPLACEMENT AND REPAIR

Refer to the engineering documentation package shipped with your terminator for a list of recommended spare parts. The parts are customer replaceable. Order replaceable parts through your representative, or call 1-800-526-5142, or send a facsimile of your purchase order to 1-717-986-7605, or call:

TOOLING ASSISTANCE CENTER  
1-800-722-1111

Terminators, applicators, and testers may also be returned for evaluation and repair. For tool repair service, please contact a representative at 1-800-526-5136.

## 8. RoHS INFORMATION

Information on the presence and location of any substances subject to RoHS (Restriction on Hazardous Substances) can be found at the following website:

<http://www.tycoelectronics.com/customersupport/rohssupportcenter/>

Click on "Find Compliance Status" and enter equipment part number.

## 9. REVISION SUMMARY

Revisions to this instruction sheet include:

Added terminator part numbers to text that applies to tester.