

PART NUMBER	SMF-2432GYC-TR	REV.	D
DATE	E.C.N. NUMBER AND REVISION COMMENTS		REV.
01.15.07	E.C.N. #11148.		A
08.09.08	E.C.N. #11530.		B
11.06.08	E.C.N. #11540.		C
10.21.13	E.C.N. #11882.		D

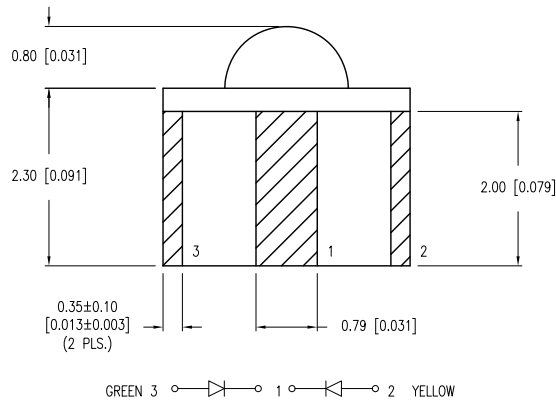

RECOMMENDED SOLDER PAD LAYOUT

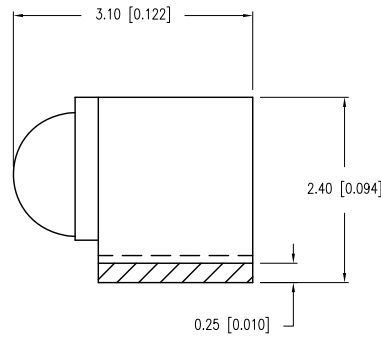
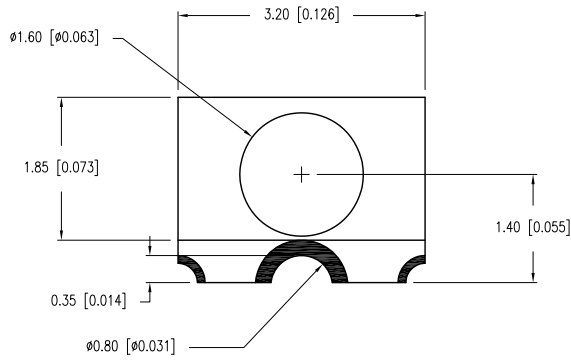
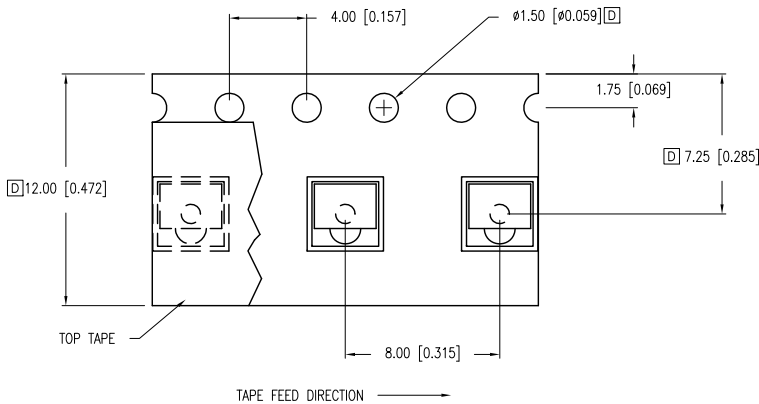
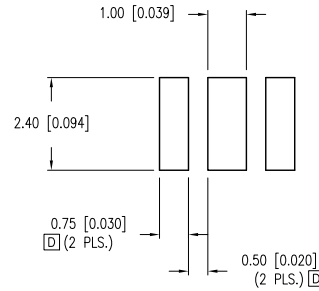

ELECTRO-OPTICAL CHARACTERISTICS $T_A=25^\circ\text{C}$ $I_f=20\text{mA}$

PARAMETER	MIN	TYP	MAX	UNITS	TEST COND
PEAK WAVELENGTH		565 (GREEN)		nm	
		585 (YELLOW)		nm	
FORWARD VOLTAGE (G/Y)		2.2/2.1	2.6/2.5	V_f	
REVERSE VOLTAGE	5.0			V_r	$I_f=100\mu\text{A}$
AXIAL INTENSITY (G/Y)		4/3		mcd	$I_f=20\text{mA}$
VIEWING ANGLE		90		2x theta	
EMITTED COLOR:	GREEN/YELLOW				
EPOXY LENS FINISH:	WATER CLEAR LENS				

LIMITS OF SAFE OPERATION AT 25°C

PARAMETER	MAX	UNITS
PEAK FORWARD CURRENT*	150	mA
STEADY CURRENT (G/Y)	25/30	mA
POWER DISSIPATION (G/Y)	85/80	mW
DERATE FROM 25°C	-1.6	mW/°C
OPERATING TEMP.	-20 TO +85	°C
STORAGE TEMP.	-30 TO +85	°C
SOLDERING TEMP.	+260	°C

* $t < 10\mu\text{s}$

NOTES:

B 1. 500 PIECES PER REEL.

C LEAD FREE REFLOW PROFILE

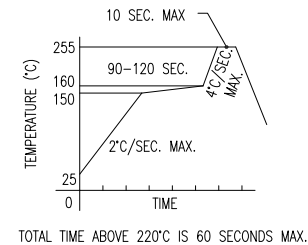

*UNLESS OTHERWISE SPECIFIED TOLERANCES PER DECIMAL PRECISION ARE: X=±1 (±0.039), X.X=±0.5 (±0.020), X.XX=±0.25 (±0.010), X.XXX=±0.127 (±0.005). LEAD SIZE=±0.05 (±0.002), LEAD LENGTH=±0.75 (±0.030). MIN.= +DECIMAL PRECISION MAX.= +0.00 -DECIMAL PRECISION UNCONTROLLED DOCUMENT

LUMEX
 Creating LED and LCD Solutions Together™

290 E. HELEN ROAD
 PALATINE, IL 60067-6976
 PHONE: +1.847.359.2790
 FAX: +1.847.359.6538
 WEB: WWW.LUMEX.COM

BICOLOR 565nm GREEN/585nm YELLOW LED, $\phi 1.6\text{mm}$ RIGHT ANGLE SURFACE MNT LED, WATER CLEAR LENS, CC.

THE SPECIFICATIONS MAY CHANGE AT ANY TIME WITHOUT NOTICE DUE TO NEW MATERIALS OR PRODUCT IMPROVEMENT.

CONFIDENTIAL INFORMATION
 THE INFORMATION CONTAINED IN THIS DOCUMENT IS THE PROPERTY OF LUMEX INC. EXCEPT AS SPECIFICALLY AUTHORIZED IN WRITING BY LUMEX INC., THE HOLDER OF THIS DOCUMENT SHALL KEEP ALL INFORMATION CONTAINED HEREIN CONFIDENTIAL AND SHALL PROTECT SAME IN WHOLE OR IN PART FROM DISCLOSURE AND DISSEMINATION TO ALL THIRD PARTIES.

DATE:	04.06.05	DRAWN BY:	JC
PAGE:	1 OF 1	CHKD BY:	-
SCALE:	N/A	APRVD BY:	JD
UNIT:	mm [INCH]		